

# *CTI-Cryogenics® Cryodyne Refrigeration System*

## *Model 22, 350, 1020 and 1050*

*Superconductor Cooling*

*MRI Coils*

*Crypumps*

*Optical Systems*

*Materials Research*

*Spectroscopy*

*Radio Astronomy*

*NMR Systems*

Helix Technology offers a family of single and two stage, closed-cycle helium refrigeration systems based on the Gifford-McMahon thermodynamic cycle, offering usable heat lift from <10K to >80K for a variety of commercial and research applications. Helix Technology has the most thoroughly proven closed-cycle helium refrigeration systems on the market today, with over 65,000 commercial systems produced to date. Helix Cryodyne Refrigeration systems consist of a refrigerator assembly, compressor assembly and customized installation kit consisting of flexible interconnecting gas lines and refrigerator cable ranging from the standard 10-foot separation length up to 300-foot lengths.



### **Exceptional Reliability**

- The most thoroughly proven closed-cycle helium refrigeration systems on the market.
- Utilizes an oil lubricated compressor pump to eliminate direct contact of highly loaded parts, resulting in virtually no wear.
- Uses pure helium gas as the refrigerant which is environmentally safe and non-flammable.
- In-line filter to minimize impact of long term contamination buildup.

**HELIX**

### Model 22 Cryodyne Refrigeration System

The Model 22 is available in both single and two stage configurations to suit a variety of applications that require a compact cryocooler.

The single stage M-22 is designed to provide up to 11 watts of heat lift at 77K for cooling of high temperature superconductors, detectors and optical devices.

The two stage M-22 is designed to provide useable heat lift under 10K and up to 1 watt at 20K and 8 watts at 77K simultaneously. Applications include spectroscopy, low temperature thermometry, amplifier cooling and LASER frequency tuning.

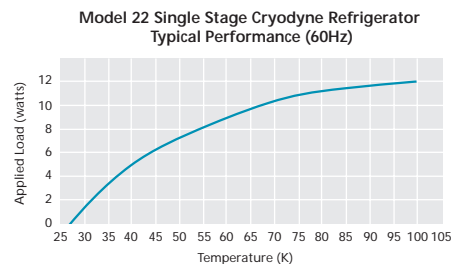
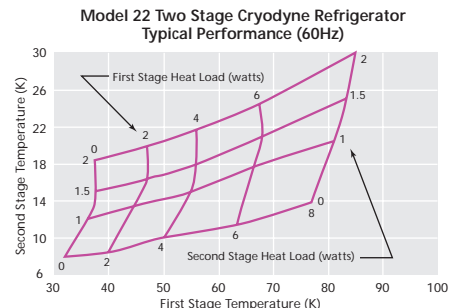
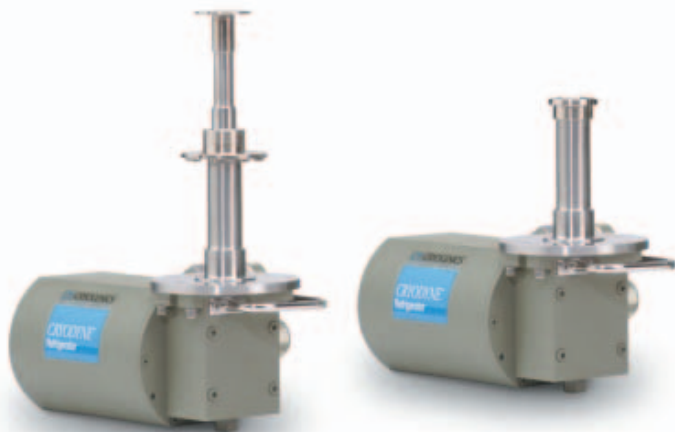

### Model 350 Cryodyne Refrigeration System

The Model 350 is available in both single and two stage configurations. The two stage M-350 was originally designed to cool amplifiers in satellite communication ground stations. The M-350 is the basic refrigerator that is used in the majority of cryopumps throughout the world.

The M-350 is used in many laboratory and commercial applications such as cooling low noise microwave amplifiers for radar and radio astronomy. The M-350 is used in basic materials research, matrix isolation spectroscopy and cooling of superconductors. The single stage M-350 will provide 40 watts of heat lift at 77K. The two stage M-350 will provide a heat lift of 4 watts at 20K and 20 watts at 77K simultaneously.

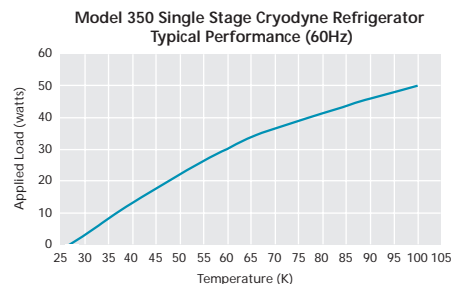
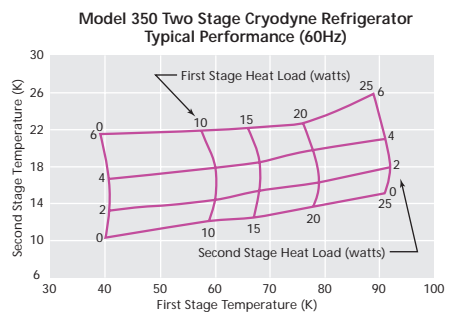

## Model 1050 Cryodyne Refrigeration System



The Model 1050 is available in both single and two stage configurations to meet a variety of high capacity cooling applications. The M-1050 is ideal for a number of High Temperature Superconductor applications that require cooling from 20K to 80K.

The M-1050 single stage system will provide 80 watts of heat lift at 77K. The M-1050 two stage system will provide 7 watts of heat lift at 20K and 65 watts at 77K simultaneously.

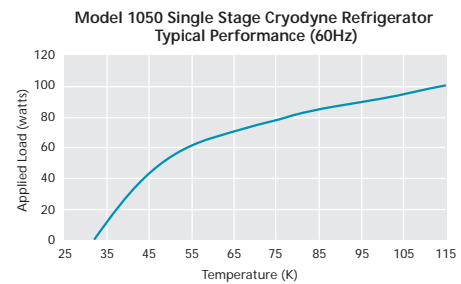
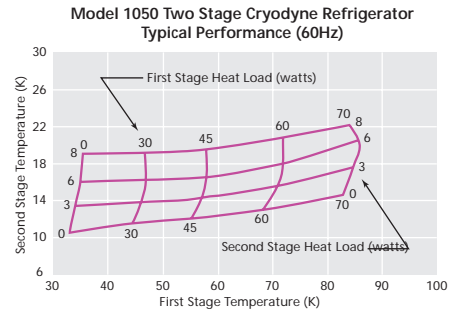

## Model 1020 Cryodyne Refrigeration System



The Model 1020 is available in a two stage configuration only. Single stage performance is available from the M-1050. The M-1020 was designed for high capacity applications such as MRI magnet shield cooling and large cryopumps. The M-1020 will provide 12 watts of heat lift at 20K and 35 watts at 77K simultaneously.

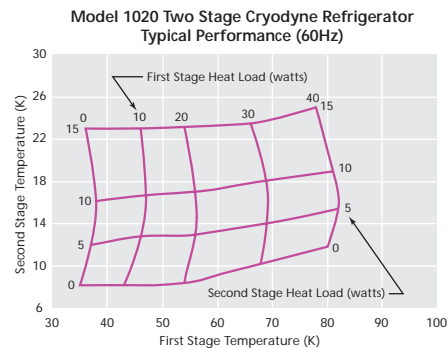

Application Notes

Compressor Matrix

Model	Pumps per Compressor	
	8200	9600
M-22 single stage	2	6
M-22 two stage	1	4
M-350 single stage	1	4
M-350 two stage	1	2
M-1020 two stage		1
M-1050 single stage		2
M-1050 two stage		1

The standard installation kit for all Cryodyne refrigeration systems includes the refrigerator power cable and the helium flexlines. Half inch ID flexlines can be utilized up to 60 feet, three quarter inch ID flexlines are recommended for 60 to 300 feet.

Model 9600 Compressor

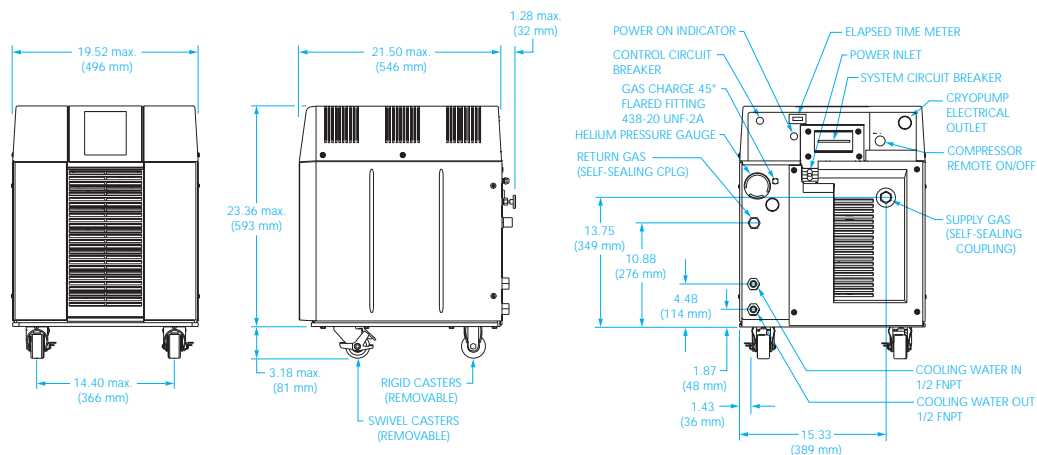

Model 8200 Compressor

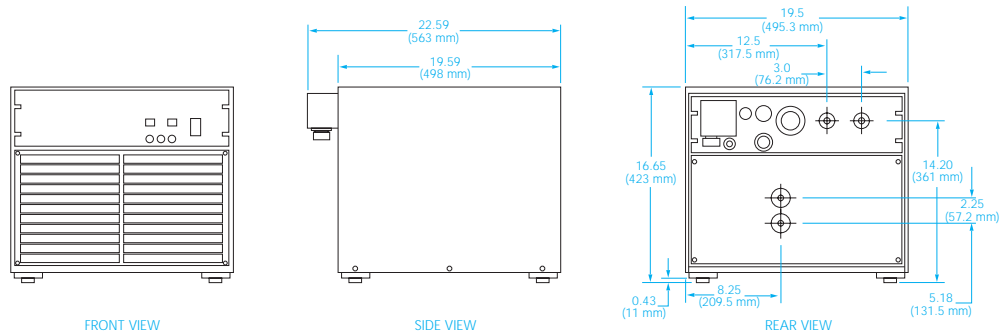

Ordering Information

Cryodyne Refrigerator System

Model	Part Number
M-22 single-stage	8104073
M-22 two-stage	8104001
M-350 single-stage	8039194
M-350 two-stage	3695576
M-1020 two-stage	8018095
M-1050 single-stage	8004502
M-1050 two-stage	8004047



Helix Technology Corporation  
 Massachusetts Operations  
 Nine Hampshire Street, Mansfield, Massachusetts 02048 USA  
 Telephone: (508) 337-5000 • Toll free in USA (800) CTI-CRYO • Fax: (508) 337-5169  
 email: salessupport@helixtechnology.com Visit us online at: www.helixtechnology.com